

04 - Interfaz USB

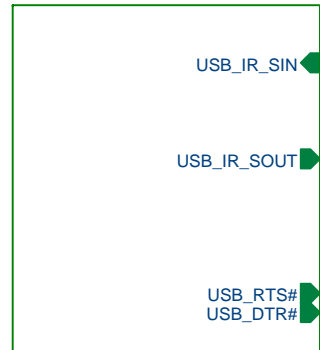

04 - Interfaz USB

02 - Alimentacion

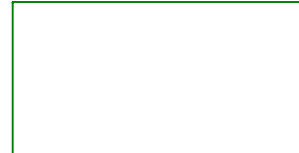

02 - Alimentacion

JMP1
TX PROG/UART

JMP2
RX PROG/UART



07 - Programacion ISP

06 - Conectores de Salida

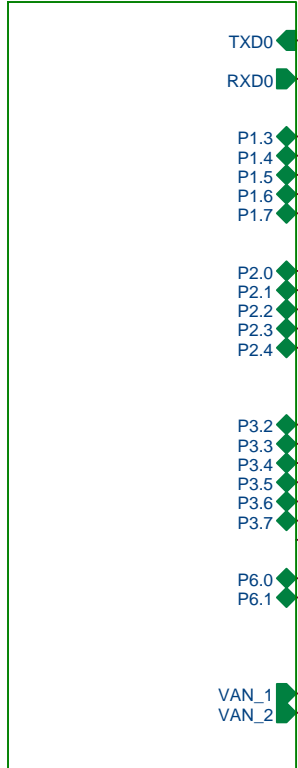

06 - Conectores de Salida

03 - Microcontrolador

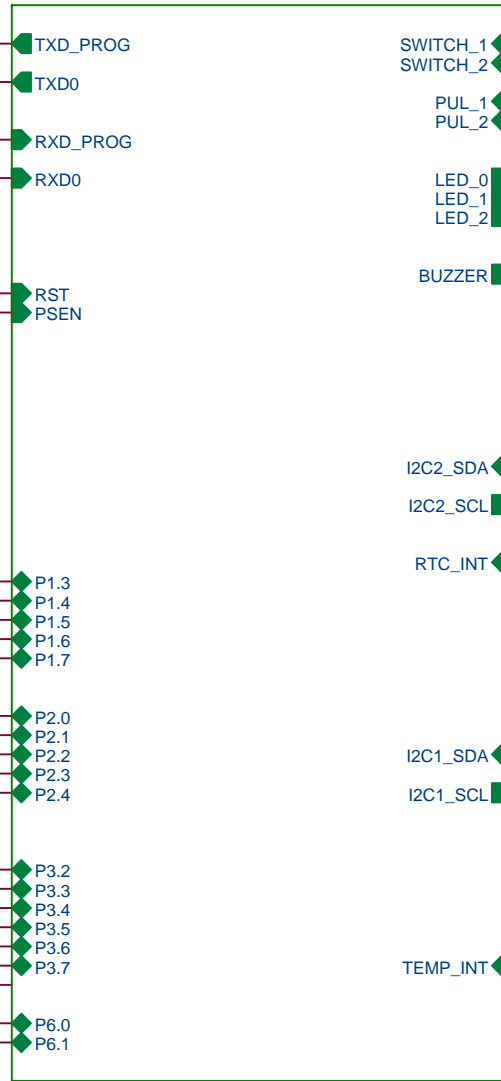

03 - Microcontrolador

05 - Interfaz Humana

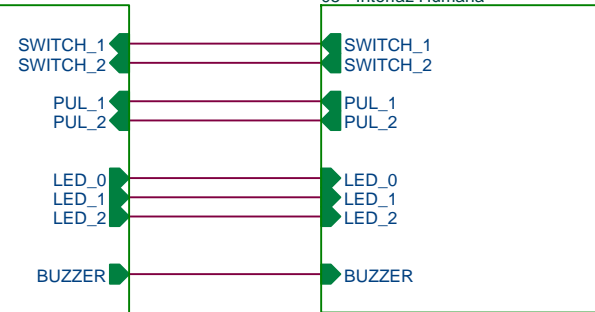

05 - Interfaz Humana

09 - Interfaz I2C +3V3 Interna

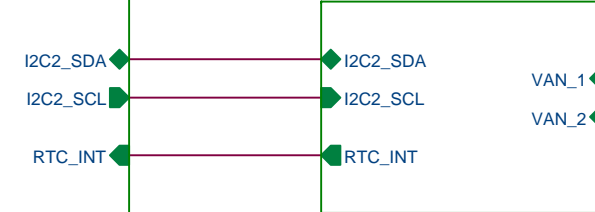

09 - Interfaz I2C +3V3 Interna

08 - Interfaz I2C +5V Externa

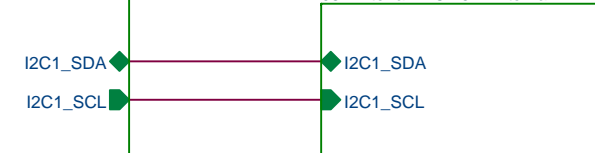

08 - Interfaz I2C +5V Externa

10 - Sensor Temperatura

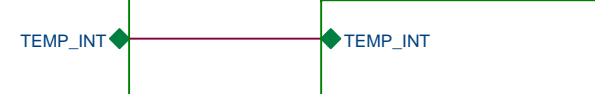

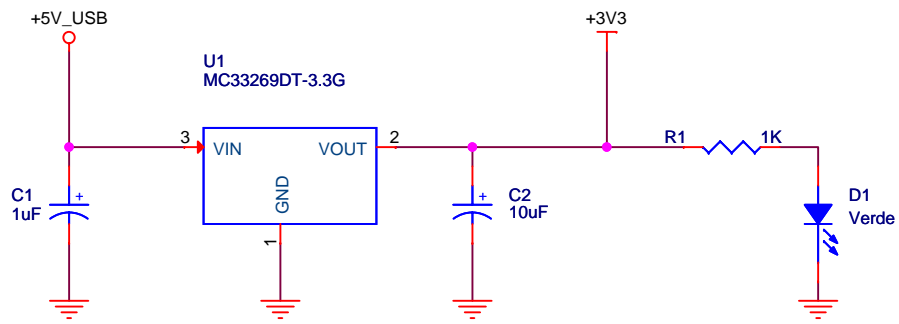

10 - Sensor Temperatura

		# DSETA Project #	
		Status: Prototype P01 www.jechavarria.com	
Title			
Main Diagram			
Size	Document Number	Rev	
A4	DS1211_01_WEB	1.0	
Date:	Thursday, April 04, 2013	Sheet	1 of 11

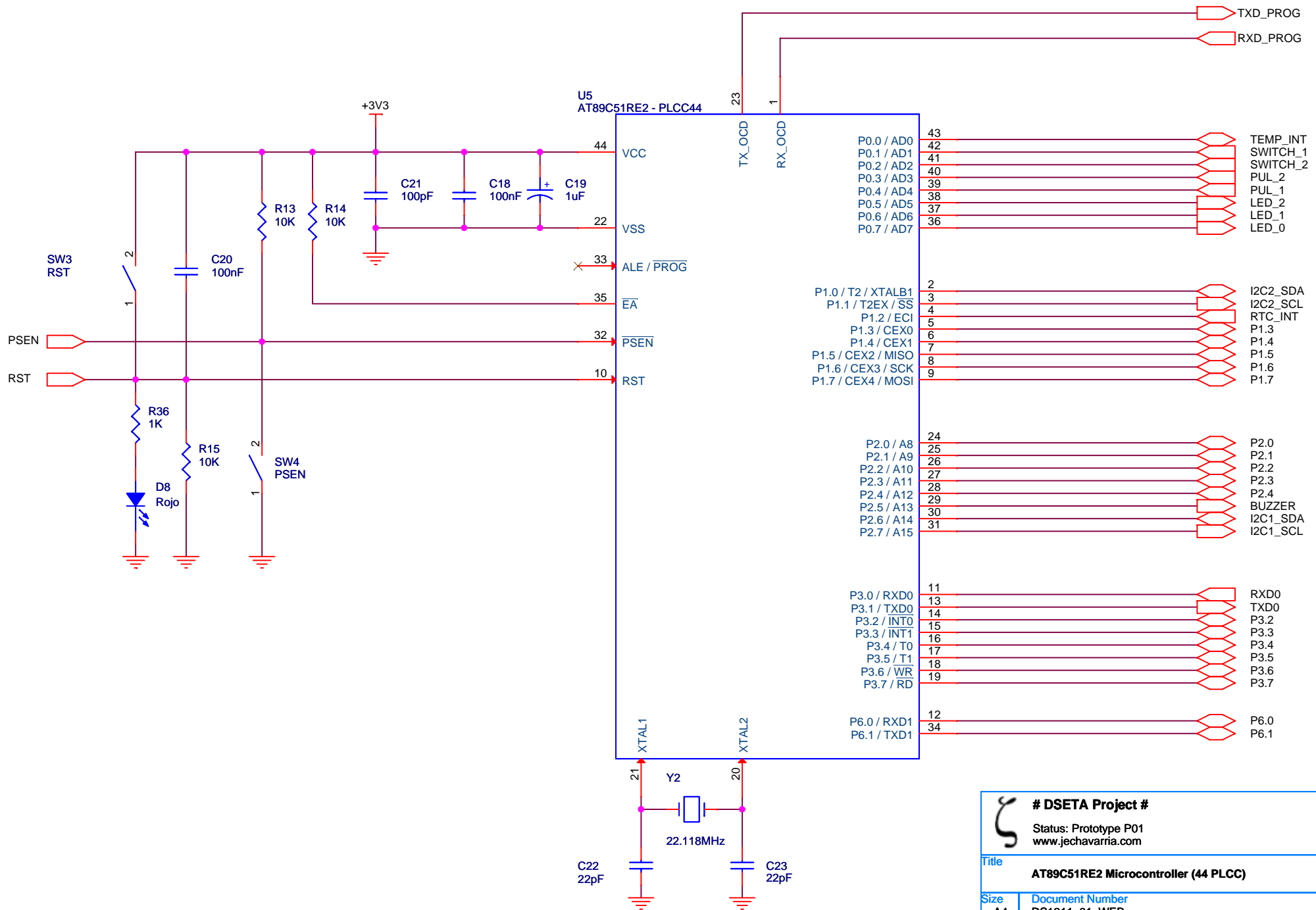

 # DSETA Project #	
Status: Prototype P01 www.jechavarria.com	
Title Power Supply (USB)	
Size A4	Document Number DS1211_01_WEB
Date: Thursday, April 04, 2013	Rev 1.0
Date: Thursday, April 04, 2013 Sheet 2 of 11	



 # DSETA Project # Status: Prototype P01 www.jechavarria.com		
Title AT89C51RE2 Microcontroller (44 PLCC)		
Size A4	Document Number DS1211_01_WEB	Rev 1.0
Date: Thursday, April 04, 2013		
Sheet 3 of 11		

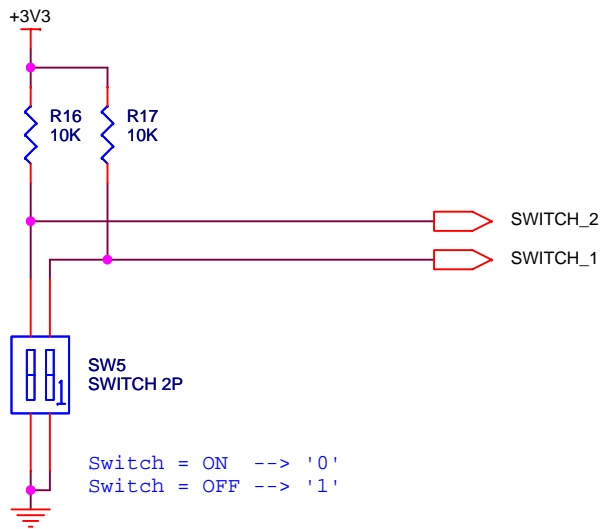

Switches

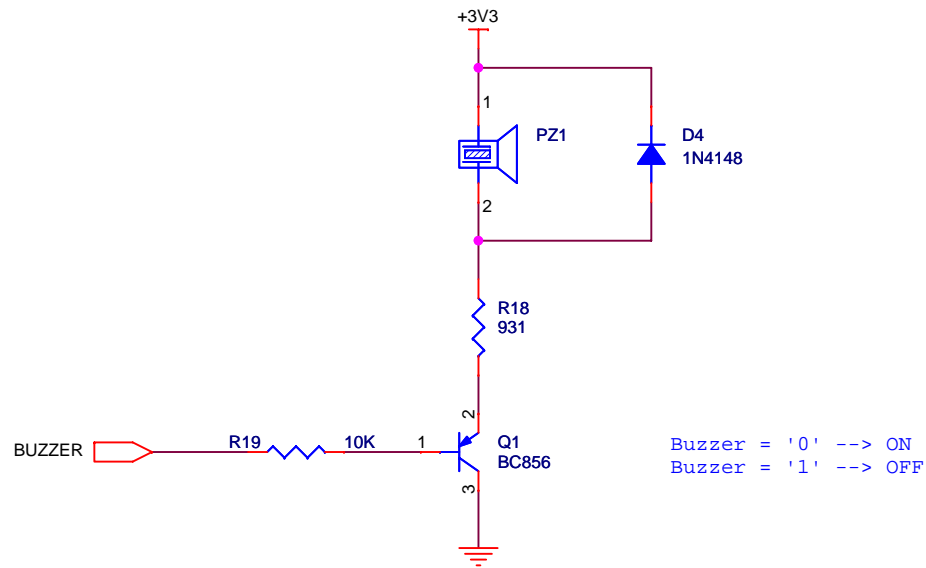

Buzzer

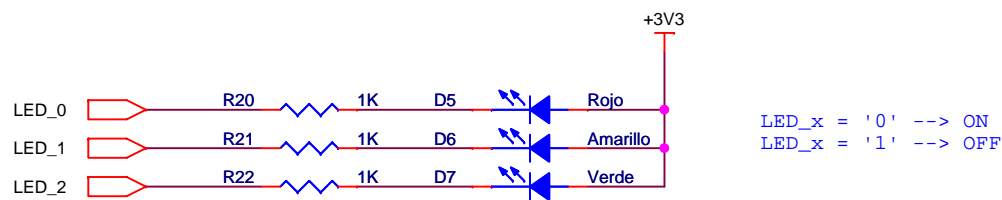

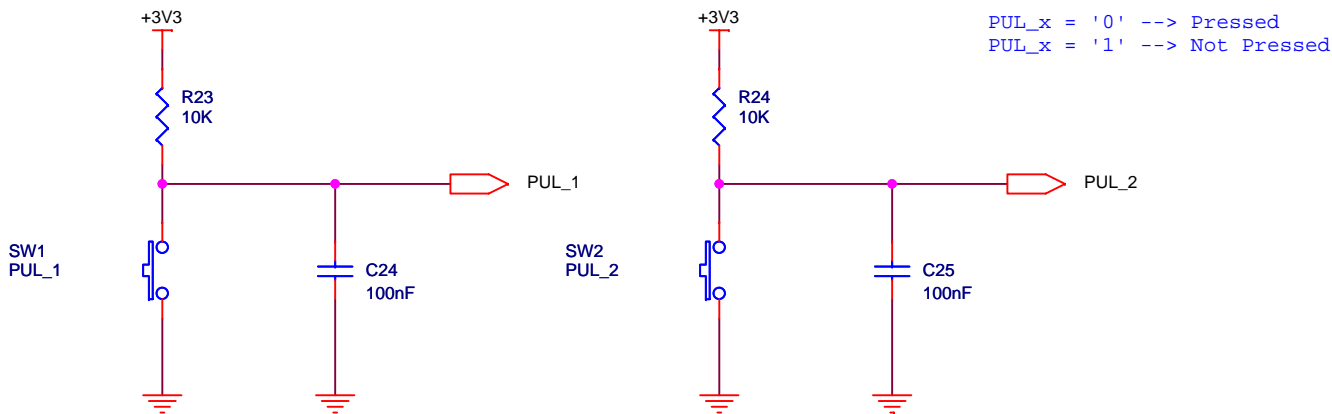

General Purpose Led's

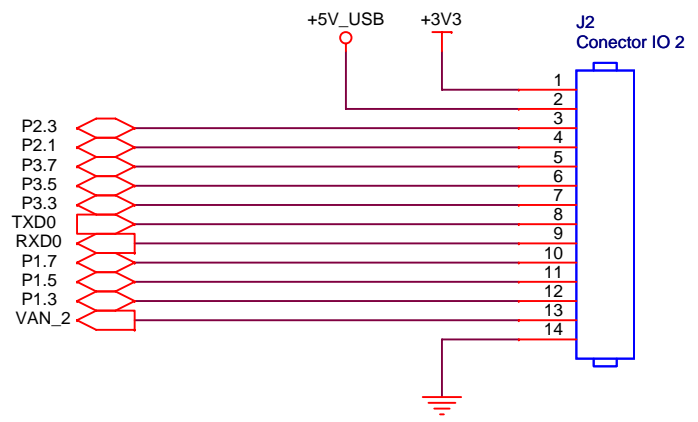
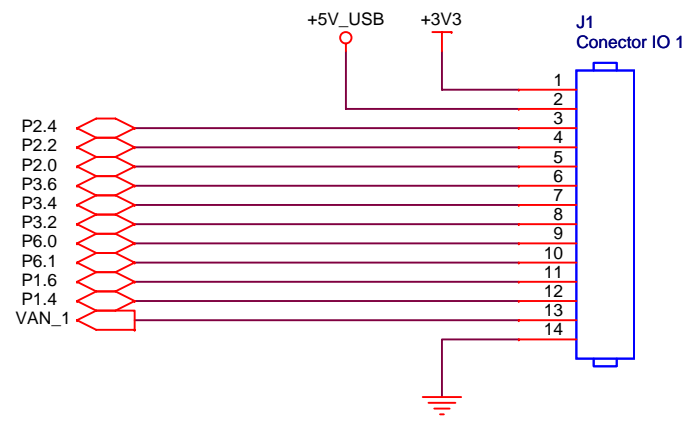

Pushbuttons

 # DSETA Project #		
Status: Prototype P01 www.jechavarria.com		
Title Human Interface (Pushbuttons, Switches and Led's)		
Size A4	Document Number DS1211_01_WEB	Rev 1.0
Date: Thursday, April 04, 2013		Sheet 5 of 11



 # DSETA Project #	
Status: Prototype P01 www.jechavarria.com	
Title	
Output Connectors	
Size	Document Number
A4	DS1211_01_WEB
	Rev
	1.0
Date:	Sheet 6 of 11
Thursday, April 04, 2013	

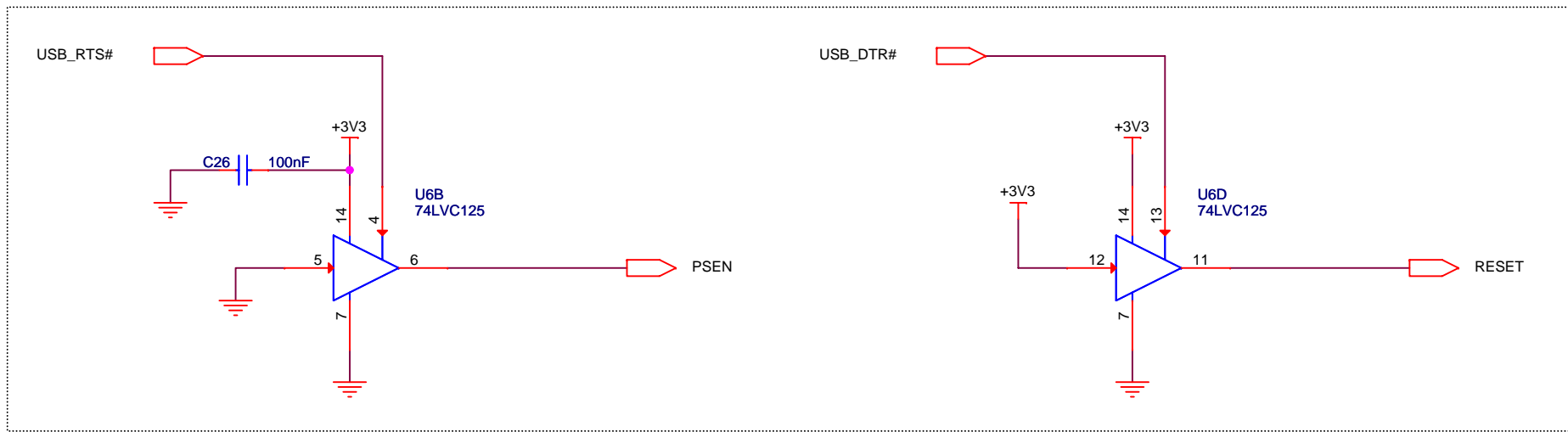

AUTO - ISP

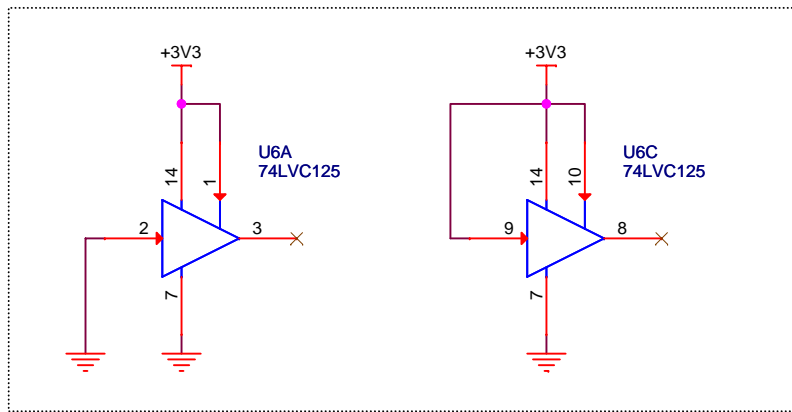

 # DSETA Project # Status: Prototype P01 www.jechavarria.com		
Title ISP Programming USB)		
Size A4	Document Number DS1211_01_WEB	Rev 1.0
Date: Thursday, April 04, 2013	Sheet 7	of 11

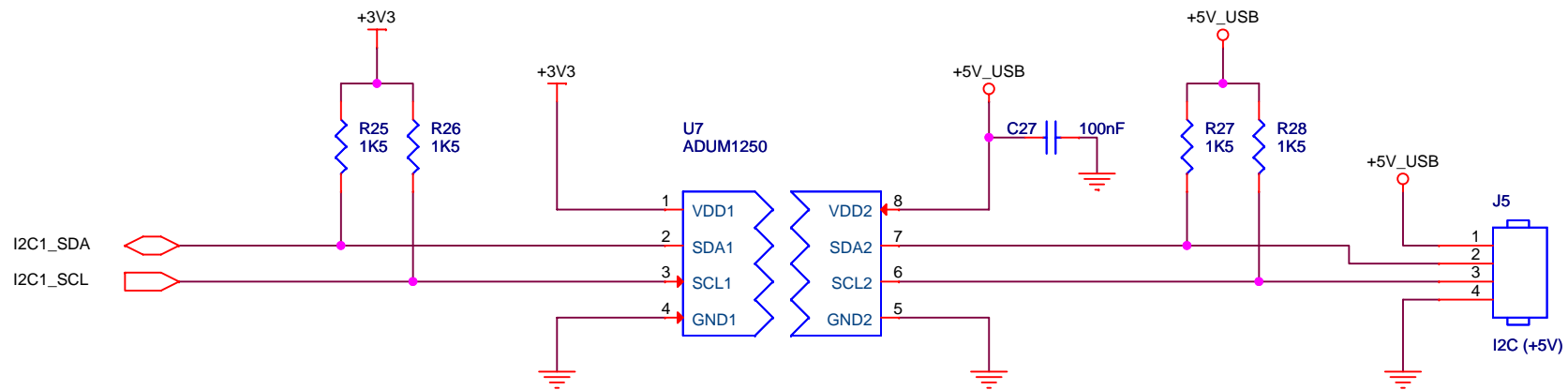

 # DSETA Project # Status: Prototype P01 www.jechavarria.com	
Title I2C +5V External Interface	
Size A4	Document Number DS1211_01_WEB
Date: Thursday, April 04, 2013	Rev 1.0
Date: Thursday, April 04, 2013 Sheet 8 of 11	

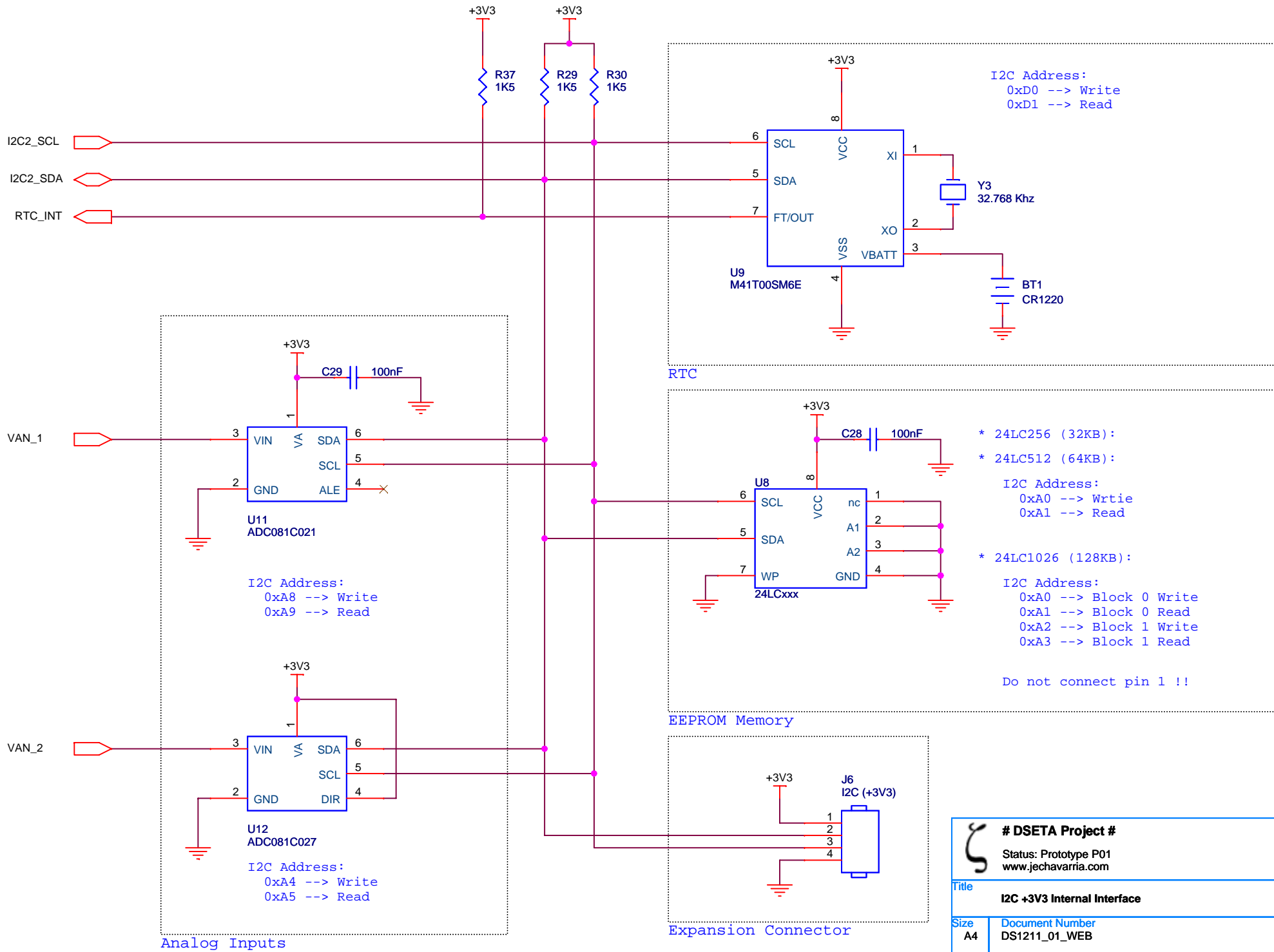

 # DSETA Project # Status: Prototype P01 www.jechavarria.com	
Title I2C +3V3 Internal Interface	
Size A4	Document Number DS1211_01_WEB
Date: Thursday, April 04, 2013	
Sheet 9 of 11	
Rev 1.0	

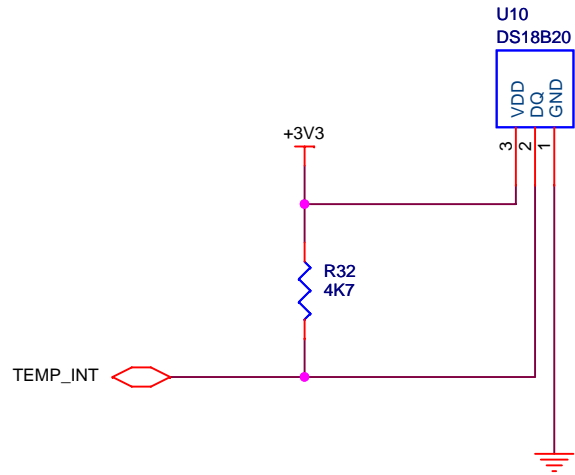

 # DSETA Project # Status: Prototype P01 www.jechavarria.com	
Title 1-Wire Temperature Sensor (DS18S20)	
Size A4	Document Number DS1211_01_WEB
Date: Thursday, April 04, 2013	Rev 1.0
Date: Thursday, April 04, 2013 Sheet 10 of 11	

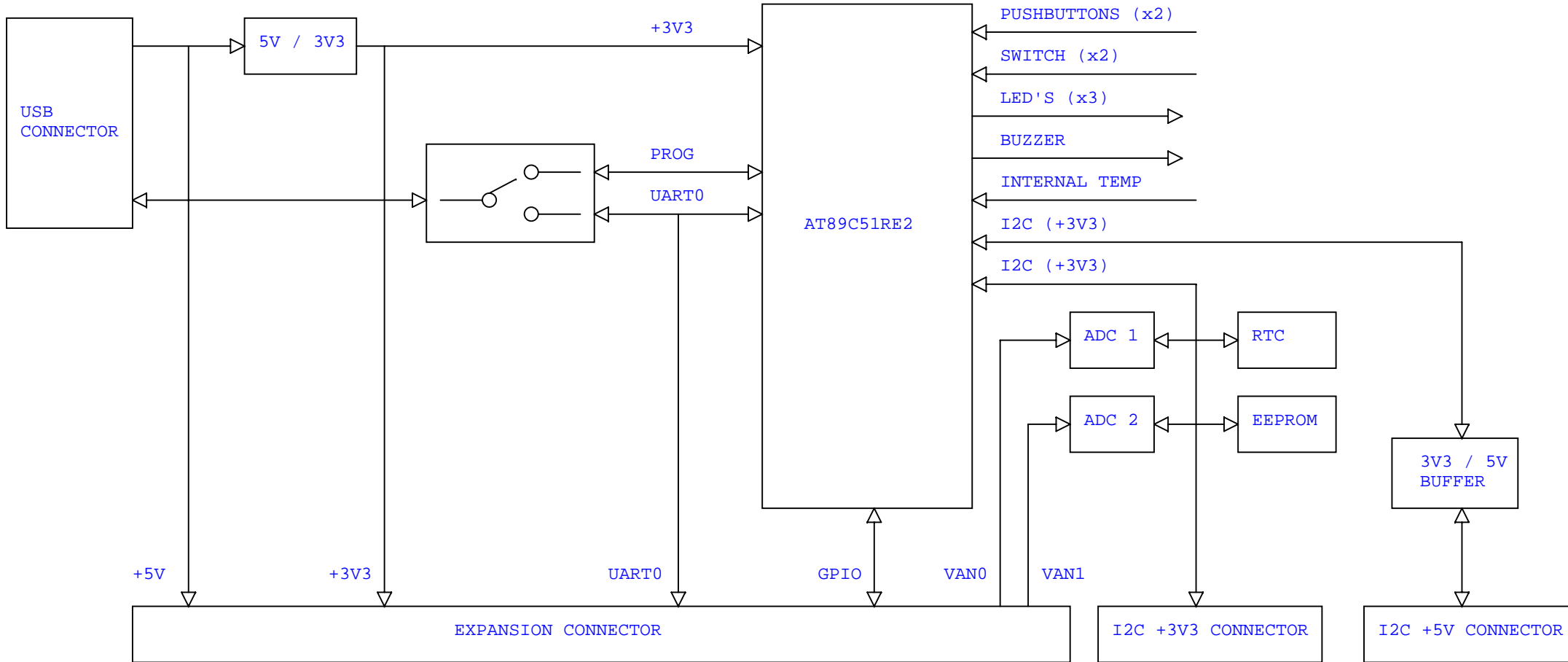

 # DSETA Project #	
Status: Prototype P01 www.jechavarria.com	
Title Block Diagram	
Size A4	Document Number DS1211_01_WEB
Date: Thursday, April 04, 2013	
Rev 1.0	
Sheet 11 of 11	